

材質	處理	附屬品
SS400	染黑	推力華司(含油金屬) 襯套(S45C-D/染黑)
SUS304	-	推力華司(SUS304/氮化處理) 襯套(SUS303)

鐵品號	庫存	不銹鋼品號	庫存	調整螺絲	L	H	A	P	B	J	G	N	D	Q	d
WAT-BLB04D06Z	△	WAT-BLB04D06S	△	M4	25	13	6.5	15	6.5	18	1.5	4.2	6.8	11	3.5(M3用)
WAT-BLB05D07Z	△	WAT-BLB05D07S	△	M5	30	14	7	18	7	19		5.2	8	12	4.5(M4用)
WAT-BLB06D07Z	△	WAT-BLB06D07S	△	M6	35	15	7.5	22	7.5	21	2	6.2	9.2	13	5.5(M5用)
WAT-BLB08D09Z	△	-	-	M8	43	18	9	28	9	24		8.3	12	16	6.6(M6用)
WAT-BLB10D11Z	△	-	-	M10	50	22	11	32	11	29	2.5	10.3	14.5	20	9(M8用)

備註

· 亦可使用在張力調整器

訂貨：  交期：  天  
WAT-BLB04D06Z

使用例

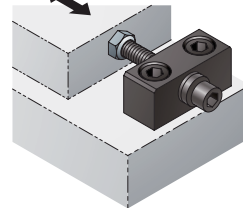
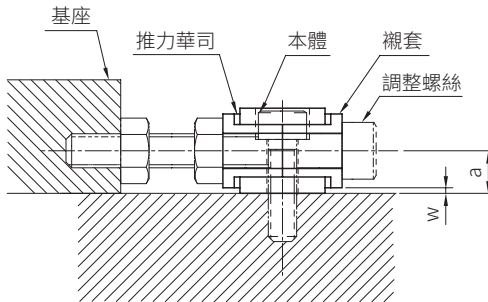

· 螺絲、螺帽需個別購買

調整螺絲	寸法(mm)	
	a	W
M4	6.5	1
M5	7	
M6	7.5	
M8	9	
M10	11	

w：襯套和本體上面的間隙